

GB



CHINESPORT SPA
Via Croazia 2 – 33100 UDINE
(Italy)
Tel. ++39 0432 621621
Fax ++39 0432 621620
www.chinesport.com

BA No.: 02.09.104/01-12



User Instructions

Standing Up Hoist – James 150

Art. No.: 14510

Serial Number

Dimensions / cm

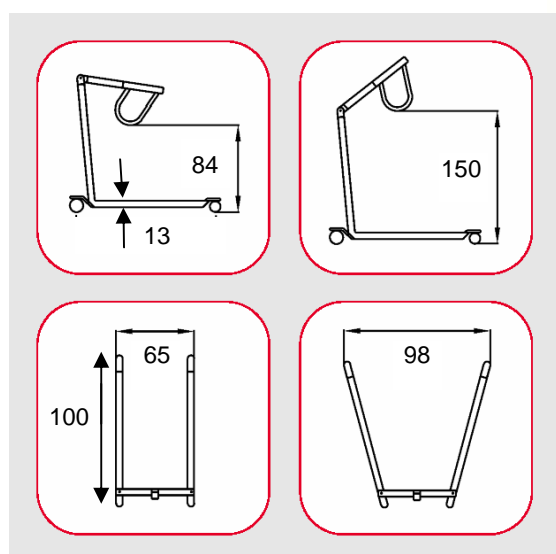

process tolerance: +/- 1,5 cm



Important advisories!

- Read this User Instructions **before first time use** of the Hoist and keep it at hand for the user.
- Adhere to all advisories, especially the safety advisories.



Product description

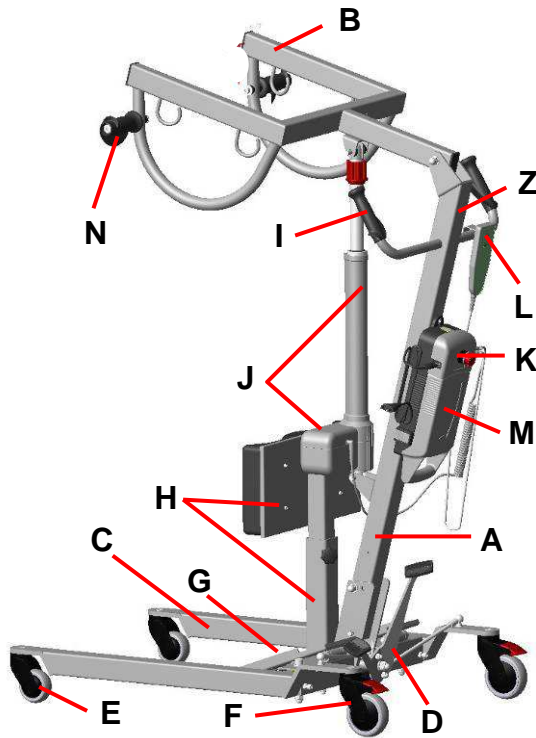

Picture shows:

A	Main Column
B	Forked arm
C	Base frame
D	Foot pedal
E	Swivel castors, front
F	Swivel castors with wheel locks
G	Front plate with anti-slip pad
H	Holder with knee protection (height-adjustable)
I	Handle bow with soft handle
J	Drive system (motor, hoisting unit)
K	Control unit
L	Hand switch
M	Rechargeable battery
N	Soft handle for forked arm (accessory)
Z	Nameplate for product (behind the column)

Nameplate

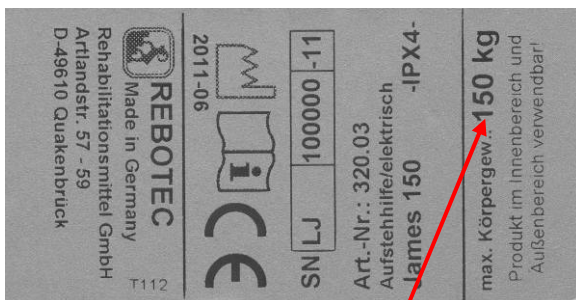

Always observe allowable maximum patient body weight!

The name-plate is very important for product identification, and thus must not be removed.

Table of contents

1.	General advisories	3
1.1	Introduction	3
1.2	Intended proper use	3
1.3	Operating comfort	3
1.4	Accessories / sling	3
2.	Warranty	3
3.	Spare parts ordering, complaints	3
4.	Re-use, lifetime	3
5.	Disposal	3
6.	Symbol advisories	3
7.	Safety advisories for use	4
8.	Product specifications	4
8.1	Delivery scope	4
8.2	Technical specifications	4
9.	Accessory, Spare parts	5
10.	Setting up for use	5
11.	Charging the battery	7
11.1	Rechargeable battery	7
11.2	Connecting and charging	7
11.3	Charge level	
11.4	Removing the rechargeable	7
12.	Emergency OFF function	7
13.	Manual switch	8
14.	Wheel brakes	8
15.	Emerg. lowering / jam. protection	8
15.1	Electrical emergency lowering	8
15.2	Mechanical emergency lowering	8
16.	Stability – spreading the base	8
17.	Forked arm (carrier for sling)	9
18.	Troubleshooting	9
19.	Care	9
20.	Maintenance	10
21.	Spare parts	11



We recommend, if possible, keeping the packaging for later transport. This will allow secure packaging in the event of a return transport.



1. General advisories

1.1 Introduction

In these User Instructions you will find information and advisories for start-up, use, operation, maintenance and care of the Standing Up Hoist James 150.

1.2 Intended proper use

The Standing Up Hoist is for use in care facilities, clinics and home purposes. The lifter described herein is exclusively for moving (lifting and transferring) a patient in a sling.

 **max. carrying load 150 kg**

The Standing Up Hoist may not be used for longer transport distances, or to other floors, or travel over uneven surfaces. It may not be used for other purposes such as transporting other objects. Also observe the local ambient conditions when using the Standing Up Hoist (**see: page 4 / section 8.2**).

1.3 Operating comfort

The Standing Up Hoist is equipped with an electrical hoisting unit, low charge protection, emergency lowering, emergency OFF function and a rechargeable battery.

The rechargeable battery allows the Patient Hoist to be used independently of an external energy supply for a certain period of time (depending on the charge level of the battery) and so increases mobility during use.

The base frame can be spread apart simply by activating the foot pedal, and thus increases stability. For providing firm footing, the foot-plates are equipped with anti-slip pads and the unit has a height adjustable holder for the knee distance.

The rear castor wheels can be easily locked with the brake lever using your foot.

Using the hand switch, the lifter arm can be moved up or down without any jerky movement and steplessly via a motorised drive unit.

1.4 Accessories / sling

Various sling systems are available as accessories for individual seating requirements and areas of applications.

Use only REBOTEC accessories, as only these can assure a trouble-free and safe function.

2. Warranty

There is a **2-year warranty** on the Standing Up Hoist James 150. A prerequisite for the warranty is use in accordance to the requirements outlined herein, as well as conducting regular maintenance. Excluded are all wear parts.

Not observing the User Instructions, improper maintenance, unauthorised modifications done to the product without the manufacturer's permission automatically lead to the immediate nullification of warranty and product liability (**see: Maintenance**).

The delivery date written on the delivery note applies as the valid start date of the warranty period.

3. Spare parts orders, complaints

To exclude incorrect spare parts deliveries and to ensure rapid processing of complaints, always provide the product name, serial number (SN) and the product's year of manufacture. You can find this information on the Lifter's nameplate.

4. Re-use, lifetime

The product is designed for re-use. The re-use (lifetime) depends on the product's condition.

Before re-use, maintenance of the hoist must be conducted and the applicable instructions concerning safety, care, and maintenance must be fully adhered to.

The expected lifetime of the Standing Up Hoist can be **up to 5 years** when used properly and the safety instructions, maintenance intervals and care instructions are followed.

Beyond this time period, the Standing Hoist can be used further if it is still in a safe condition (after a complete inspection).

5. Disposal

This product consists of various combined materials (metal, plastic, electrical parts, power pack battery) and so it cannot be disposed of through the regular household waste. This must be done separately according to the local and national regulations for environmental protection and raw material recycling.

Please contact your local disposal company or environmental officials for further information.

6. Symbol advisory

The following symbols are found on the nameplate and in the User Instructions.

Symbol - nameplate:



Read the User Instructions booklet!



Product conforms to the Medical Products Directive 93/42/EEC.



Year of Manuf.
Product



Serial No
Product

**Symbols in the User Instructions:****Important advisory
or information!****GB**

Language

**Caution – Follow safety advisories!**

Care



Maintenance

Protection class: IPX4**X-** No identification number given**4-** Protection against water spray from all directions**7. Safety advisories for use****When using the Standing Up Hoist, the following safety advisories must be observed:**

- Before the first use, the User Instructions must be read completely in order to avoid faulty operation or hazards.
- Before each use, check the Patient Hoist for visible damage or deficiencies.
- Operating and adjusting the Patient Hoist must be done only by persons who are knowledgeable and trained on how to properly handle the Patient Lifter. This requires the ability to use the unit with patients.
- Standing Up Hoist used in wet rooms may be exposed to humidity moisture, chlorine and heat, which can lead to oxidation that appears as a white coating.
- When functional faults or damage of any type occurs, then the Patient Hoist may not be used.

Danger of breakage!

- **The max. allowable load of 150 kg may not be exceeded because no safe operation can be assured.**
- Whenever using a sling, be sure that it is securely hung to the forked arm of the Standing Up Hoist. Do not use any sling that shows signs of damage.
- Do not place any objects between the main column and the drive axis. No perpendicular loads may be applied to the drive axis.
- The patient must not hold onto the drive axis.
- No weight loads may be hung onto the forked arm for an extended time period.

Danger of injury !

- The Standing Up Hoist may not be operated while it is being charged up.
- The Patient Hoist may be used only inside on even, slip-free surfaces. Using the Patient Hoist on slopes, grades or inclinations must be avoided due to the increased risk.

- Use caution when travelling in tight spaces. Paths used by the Standing Up Hoist must be cleared before they are travelled on.
- Sudden movements and pushing, as well as patient-swinging must be avoided because of an increased risk of an accident.
- Never leave the patient unsupervised when using the Standing Up Hoist! An unforeseen movement or action by the patient may lead to a possible risk of injury.
- In the event of an emergency lowering of the patient, use extreme caution to avoid putting the patient in danger. In difficult situations, seek the assistance of another person.
- Check for a secure connection between the forked arm and the Hoist arm.

Danger! Function hazard!

- It must be assured that no humidity reaches inside the electrical systems.
(Observe protection class!)
- Do not open up the control / drive / battery unit or hand switch systems!
- Do not charge up the rechargeable battery in wet rooms (e.g.: bathrooms, shower stalls).

8. Product specifications**8.1 Delivery scope**

The product has been carefully inspected in the factory for freedom of defects and for completeness. After having received it, carefully check over the product for possible transport damages and for completeness.

- 1 Standing Up Hoist "James 150" (main frame)
- 1 control unit
- 1 rechargeable battery
- 1 recharging cable
- 1 manual switch with hanging grip
- 1 User Instructions

8.2. Technical specifications

We reserve the right to make technical developments and improvements with respect to the design shown in the User Instructions.



Ratings	Standing Up Hoist James 150	
Carrying load	max. 150 kg (body weight)	
Product weight	50 kg (without accessories)	
Space req. max. L x W x H	Standing: 110 x 65 x 200 cm (Lifter arm all the way up)	
Wheels Ø	Front: d = 75 mm Rear: d = 100 mm with lock	
Turning Ø	ca.115 cm	
Knee pro. height	50 cm to 75 cm (knee midpoint)	
Lift height	84 cm to 150 cm	
Lift cycles	Approx. 45 double lifts (depending on wt. and charge)	
Lifting unit	Steples and without jerking	
Protection class	II	
Switch duration	2 min operation / 18 min. pause	
Voltage	230-240V AC/50Hz (control unit)	
Control unit	IP54	24V DC / 5A
Drive, compl.	IP54	24V DC / 5A
Hand switch	IPX4	24V DC
Charging unit	IPX4	230V/24V, 500mA
Power-pack	IP54	24V DC / 5Ah
Operate/storage	5°C to 45°C / -10°C to 50°C	
Operate/storage	Air humidity max. 85%	
Safety	<ul style="list-style-type: none"> - Mechanical emergency lowering - Power-pack low charge - Power surge switch off 	

process tolerance: +/- 1,5 cm

9. Accessory, Spare parts

Article No.	Name, description
320.60	Soft handle for forked arm / 2 pice
02.09.104	User Instructions - James 150
02.10.066	Maintenance book
02.10.063	Instruction aid - sling

10. Setting up the for use

The product is delivered partially pre-assembled. The following assembly instructions must be carried out before first-time use.

Step 1: Unpack

Remove the Standing Up Hoist out of the packaging and place it on a level floor. Lock the wheel castors (see: page 8, section 14) so that the Hoist cannot roll away.



Step 2: Install the control- and battery unit

Securely screw the control unit (K) to the column (A) using both M6x16 screws (1) (included in the accessories) using an SW5 Allen key. Be sure that the red button of the control unit is correctly positioned, facing the handle!

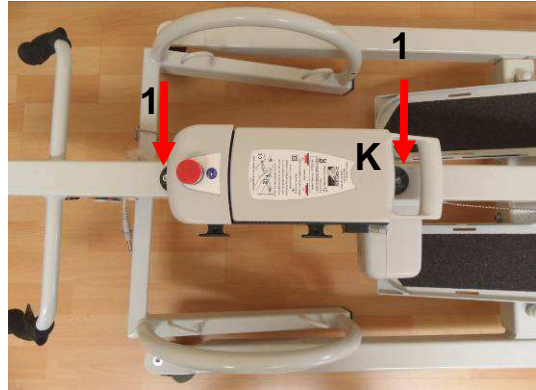

Step 3: Set up the column

Before setting up column (A), first unlock the wheel brakes (F). To avoid damaging the paint coating on the column, first straighten the pedal (D).

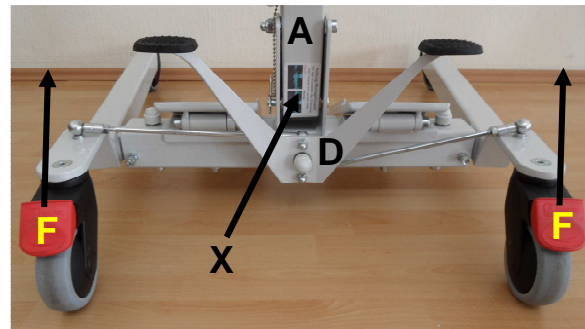

Next lock the wheel brakes!

Step 4: Install the column

Remove the ring (1) "or spring clip (2)" from the bolt (3) and then pull the bolt completely from the hole.

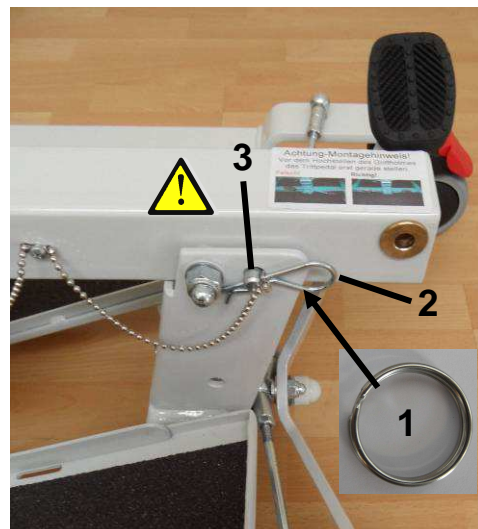



The column (A) can now be set up together with the forked arm (B).

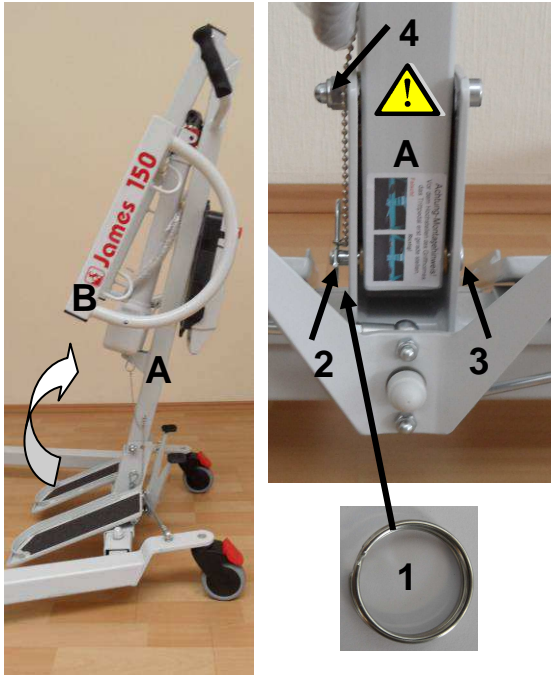

By inserting bolt (3) into the borehole, the column (A) is arrested.

Next secure the bolt against slipping out by installing the spring clip (2) "or ring (1)" and then tighten the M10 cap nut (4) to the column (A).

Step 5: Install the Hoist axis

To mount the drive motor to the Hoist axis, first remove the key ring and bolt (1) "or spring clip (2)" from the hole of the Hoist arm (A).

Next lift up the Forked arm (A) and align the borehole of the Hoist axis (X) with the Forked arm.

Then insert the bolt and secure it with the key ring. Now the Forked arm is secured.

Be sure that the key ring or spring clip is fully closed!

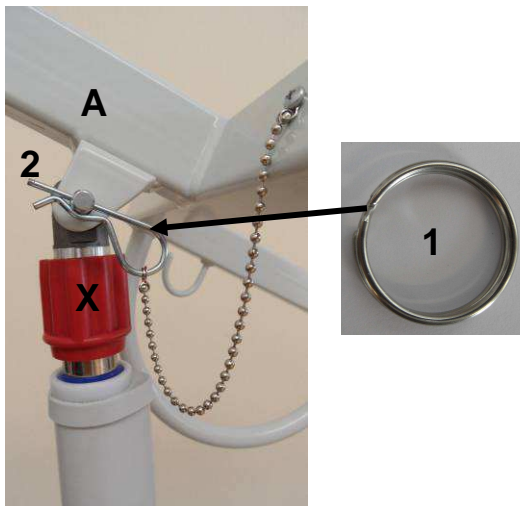

Step 6: Install the holder with knee protection

Unscrew the two screws (1) from the holder plate (A), and fix the holder (B) with the knee protection. By solving the star grip screw (2) the knee protection can be adjusted in height.

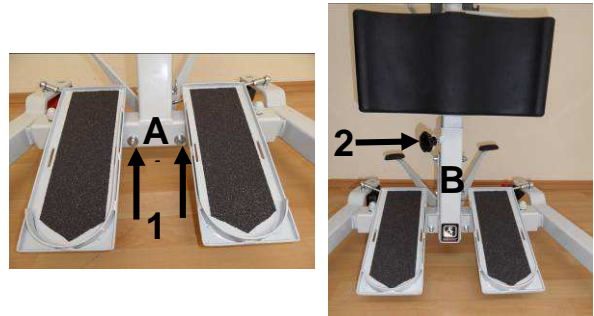

Step 7: Cable connections

Carefully insert plug (1) of the drive unit into the jack (X) and the plug (2) of the hand switch into jack (Y) on the side of the control unit.

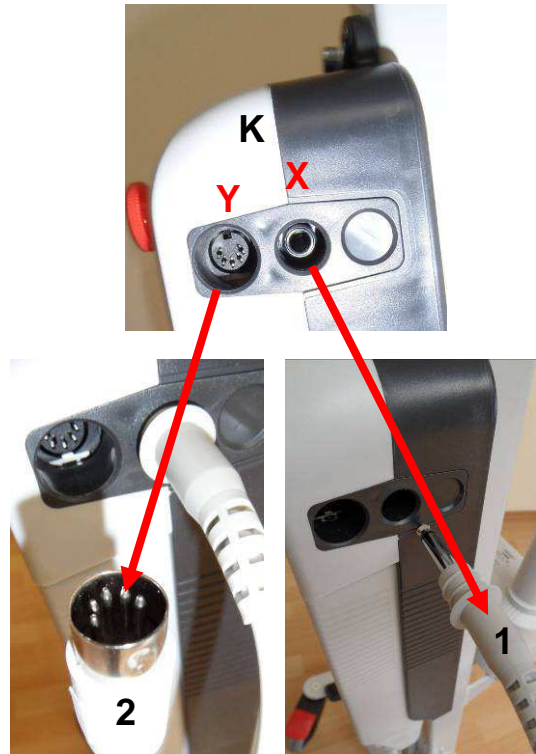

Step 8: Emergency OFF button

Before starting up the Patient Hoist, the emergency OFF button must be deactivated. To do this, rotate the button clockwise until it pops out.

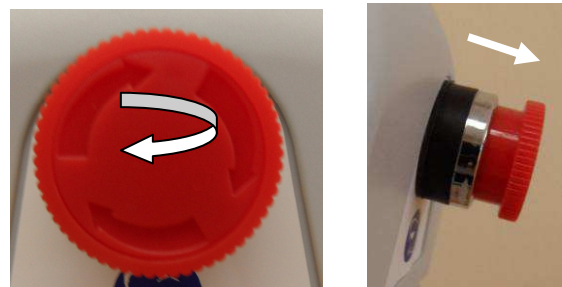



11. Charging the battery

11.1 Rechargeable battery

If the lifting and lowering of the Hoist arm becomes noticeably slower, then the battery charge is too low. **Recharge the battery as soon as possible!** This extends the lifetime of the rechargeable batteries. Rechargeable batteries that are not used for an extended period of time should be recharged every 3 months in order to avoid low charges. Otherwise the charging capacity of the battery is negatively impacted. The lifetime of the batteries depends on the loading and the charge level.

11.2 Connecting and charging



Observe the following instructions!

- Check over the charging unit to be sure that the connector cables or the plugs are not damaged. **DO NOT USE** cables or plugs that are damaged!
- Check the power mains supply (230-240V/50Hz) and power supply fuse protection for the charging unit.
- The charging unit and the rechargeable battery may not be opened under any circumstances!
- **The Patient Hoist may not be operated while it is being charged!**

Insert the flat plug (1) of the charging cable (see accessories) into the jack (C) of the control unit and then insert the plug (2) into the wall outlet.

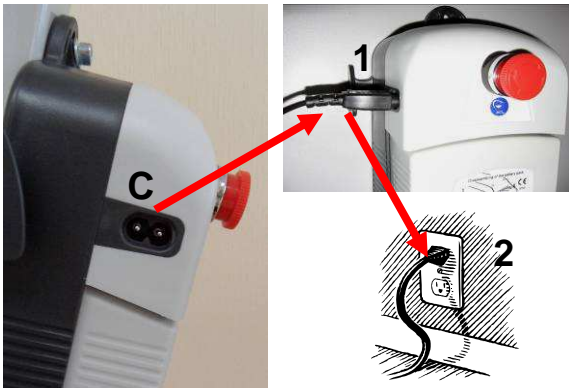

Depending on the battery charge level, the charging process can be as long as **10 hours**. If the charging process lasts longer than 10 hours, then the rechargeable battery or the charging unit is defective.

After charging, pull out the plug from the outlet and then wind the cable around the holder for storage.

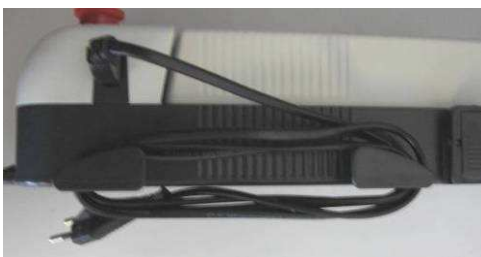

11.3 Charge level / indicator lamps

The LED charge level indicator lamp is located below the window of the control unit. The LED display is visible when looking directly at the window from above.

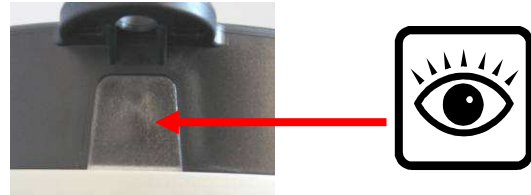

Indicator / LED

- ⊗ **LED-dark:** Battery capacity is sufficient
- ⊗ **LED-green:** Battery is fully charged!
- ⊗ **LED-red:** If the red LED illuminates when activating the hand switch, then it means the battery capacity is too low.
Battery must be recharged!

11.4 Removing the rechargeable battery

The battery can be removed for replacing or for storing. Look at the diagram on the battery unit.



12. Emergency OFF function

By pressing the red **emergency OFF button**, it locks into position. The drive system is interrupted and cannot be operated with the manual switch. It is activated in emergency situations and in the event proper operation of the Standing Up Hoist is impaired.

Stop





By rotating the **emergency OFF button** clockwise, it will pop back out and is thus released. The drive unit can then be operated using the manual switch.



13. Manual switch

The drive unit is activated with the manual switch (steeples adjustment) and activates “**lifting**” and “**lowering**” of the Forked arm.

For the desired action, the button is kept pressed down. When releasing the button, the drive automatically stops.

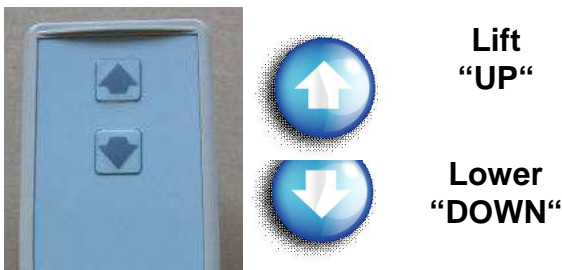

14. Wheel brakes

Both wheel brakes are an important safety feature whenever using the Patient Hoist. The back swivel castors are equipped with wheel locks and allow locking of the rear wheels.

Danger – Risk of tipping over!

Both rear wheels must be locked.



Press the wheel lock levers down with your foot. The wheels are now locked and the direction is secured. Be sure that the wheels are not swivelled inwards.



The wheel brakes can be released simply by lifting up the lever with your foot.

15. Emergency lowering / jamming protection

15.1 Electrical emergency lowering

If the hand switch is out of order due to a defect, yet the electrical system is still able to function (battery is sufficiently charged), then the lifting axis can be lowered one more time by using the emergency OFF button.

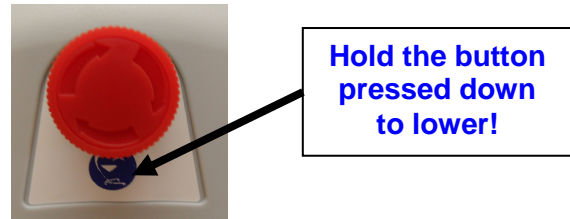

15.2 Mechanical emergency lowering

In the event the patient becomes exposed to an emergency situation, or an electrical defect occurs with the drive motor, or the control unit fails or the battery is completely uncharged, then it is necessary to use the mechanical emergency lowering system.

Before using the emergency lowering, it is absolutely necessary to interrupt the power supply from the battery. Press the emergency OFF button!

Danger-Risk of injury!

When using emergency mechanical lowering, do not stand under the Forked arm!

Start lowering
Grab the red rotary grip and pull it downwards until it clicks into position. For lowering the drive axis, grab the red rotary grip and turn it counter-clockwise.

Stop lowering
Let go of the red rotary grip and turn clockwise a half turn until it clicks into position. Lowering is now blocked.

16. Stability – spreading the base

The foot pedal allows the spreading of the base members (left and right) and thus facilitates moving the unit to the area of use. Press the foot pedal all the way down to the stop.

Danger of tipping over!

Spread the base members only when the rear wheel locks are fully disengaged!

Not spread apart

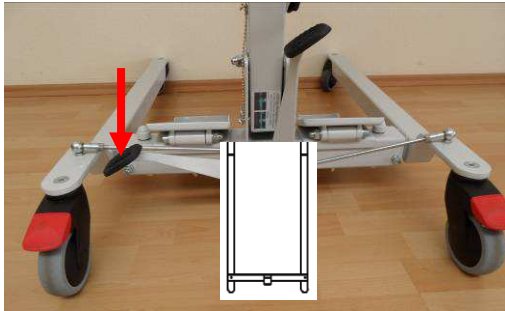

Spread apart

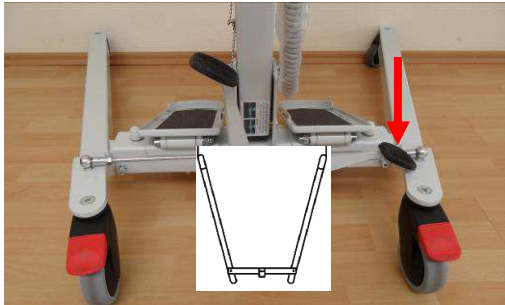

17. Forked arm (carrier for slings)

The forked arm (B) serves for attaching the sling. The sling holds the patient, who then can stand up and be moved over.

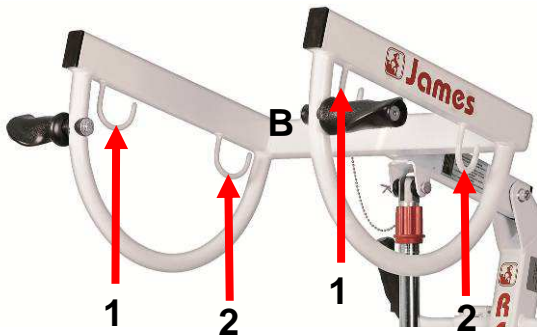

Hanging the sling **must** be done using both hooks (1 or 2) so that the load is evenly distributed.

Depending on the application, there are several different types of slings systems offered by REBOTEC. To assist you in selecting the most suitable sling system, a guide is available (see: page 5, section 9).

18. Troubleshooting

Fault	Poss. cause	Correction
Drive does not function	Emergency OFF button is activated	Disengage emergency OFF.
	Bad electrical connection	Check the connection.
	Defective power cable	Inspect the cable.
	Battery is too low	Charge up battery.
	Lift unit is jammed	Check for freedom of movement.
	Battery has no contact	Re-install battery, Check position.
Battery does not charge	No battery	Insert battery.
	Display does not illuminate green after the end of charging	Check power mains, Check power cable and contact and for damage Battery is defective, Display/LED faulty
Forked arm does not drive all the way up or down	Battery capacity is too low.	Charge up battery.
	Forked arm is jammed	Loosen the screws at the column.
Manual switch does not function	Button(s) have no function	Button(s) defective.
		Check cable / plug contact.
Greatly reduced speed, loud noise	Motor, drive defective	Do not operate the drive system. Do maintenance!

19. Care

In general the Standing Up Hoist can be cleaned using a mild conventional cleaning and disinfecting agent. Simply wipe the product with clean water and cloth, and then wipe dry with a clean cloth.

Maximum cleaning temperature of 65°C must be observed!

The Standing Up Hoist must not be washed inside an automatic washing unit!

Do not use an abrasive scouring agent or cleaner (read the product instructions!) that contain aggressive solvents (acids, thinners, benzene). Do not use stiff cleaning brushes, as these will damage the painting or cause deposits to build up on the steel parts and other materials.

Emergency lowering

The emergency lowering mechanism may not be treated with oil, grease or other lubricant. This will lead to faulty function when lowering.



20. Maintenance

Accidents or damage may be caused by the late detection of wear and/or improper use, as well as irregular or no maintenance.



For safety reasons and for preventing accidents, the Lifter must undergo a **complete maintenance at least once a year**. (Refer to the Medical Products Act and the local regulations.)

For documenting maintenance, REBOTEC offers a maintenance manual (**see: Section 9**).

Here you will find all information concerning the scope of maintenance and forms for documentation.

You can order this instruction manual or download it at our website: www.rebotec.de.

Maintenance scope

Check at regular intervals:

The time intervals depend on the frequency of use and the condition of the product.

- The product for visible damage (cracks, breakage, loose parts).
- All screw connections for tightness (especially the wheels and carrier).
- **Emergency lowering at least semi-annually** (malfunctions – carry out maintenance!)
- Rolling smoothness, castor function (replace any defective castors).
- Drive unit function, test manual switch. (Replace defective articles).
- Cable connections and plugs for damage.
- Sealing edges of the control and battery unit.
- Test the emergency OFF function.
- Inspect the accessories for deficiencies.



If you have questions concerning maintenance and repairs to the chair, then contact an authorised dealer or medical equipment supply outlet.

When making repairs, use only original spare parts from REBOTEC. Observe all advisories concerning guaranty and warranty.

Never make any unauthorised modifications or conversions to the product. These will only adversely affect the safety and function of the Lifter. **In such cases the manufacturer REBOTEC overtakes no liability.**

Follow all the instructions when ordering spare parts, re-use and product lifetime of the product. After a complete maintenance or repair of the Lifter is done, we recommend a complete cleaning for assuring hygiene. Follow the cleaning instructions.

Notes:

21. Spare parts: James 150/320.03

1	420.70.71	Linear motor drive, type B/5A)
2	420.11.72	control unit, type B/(24VDC / 5A)
3	420.11.73	battery unit, type B/(24VDC / 5Ah)
4	420.70.75	handset, type B/ (24VDC)
6	443.10.80	castor (Ø 75 mm)
7	441.10.81	castor with brake (Ø 100 mm)
8	420.00.15	pedal rubber covering
9	420.00.12	foot pedal
10	420.28.83	rod angle joint (L=280 mm)
11	420.00.84	handle Ø 22 mm
12	420.00.51	fork arm
13	420.00.60	knee protection unit complete
14	420.00.66	knee cushion
15	320.60	handle for fork arm
16	420.70.79	recharging cable



Notes:

Manufacturer :

REBOTEC® Rehabilitationsmittel GmbH
DE-49610 Quakenbrück, Artlandstr. 57-59
Telephone: (+49) 5431/9416-0
Telefax: (+49) 5431/9416-66
<http://www.rebotec.de>
E-mail: info@rebotec.de



